

A Gas Chromatographic Method for the Determination of Volatile Flavours from Foodstuffs

ERKKI HONKANEN and PERTTI KARVONEN

Laboratory of the Foundation for Chemical Research, Biochemical Institute, Helsinki, Finland

A semiquantitative gas chromatographic micromethod is described for the determination of the higher-boiling flavour substances from liquid foodstuffs. The method is based on vacuum steam distillation and extraction of the flavour compounds, followed by an accurate concentration of the extract to a known final volume, which contains the flavour compounds in about a thousandfold the concentration of the original sample. This concentrate has been used in the quantitative gas chromatographic analyses. The method is suitable for concentrations of 5 μ g-10 mg per litre and a recovery of about 50-90 % is obtained for compounds boiling at 100-250°C at ordinary pressure.

The quantitative isolation and determination of volatile flavour substances is very difficult and for the present only a partially solved problem. Most methods are based on the distillation of the flavours with steam, at ordinary or reduced pressure, and collection of the distilled substances and water in several cooling traps. The flavour compounds are then fed to a gas chromatograph column either directly or after extraction and indefinite concentration. These methods, however, only give a qualitative picture of the flavour spectrum and their value is limited to the routine checking of the flavour of foodstuffs.

The method presented here is not new in principle. It is developed and modified from the earlier methods, chiefly from the works of Weurman¹ and Strating *et al.*² The liquid sample was distilled in the special distillation apparatus shown in Fig. 1 at reduced pressure. This evaporator type distillation apparatus was found to be more effective than the normal vacuum steam distillation apparatus. The vapours were condensed in receivers, one at 0°C and two at -70°C. When necessary, the third trap was placed in liquid nitrogen for the collection of the lowest-boiling compounds. The distillate was then extracted with a mixture of pentane-ether (or with ethyl chloride) and the extract concentrated to a known final volume. This concentrate contains the flavour substances in about a thousandfold the concentration of the original sample.

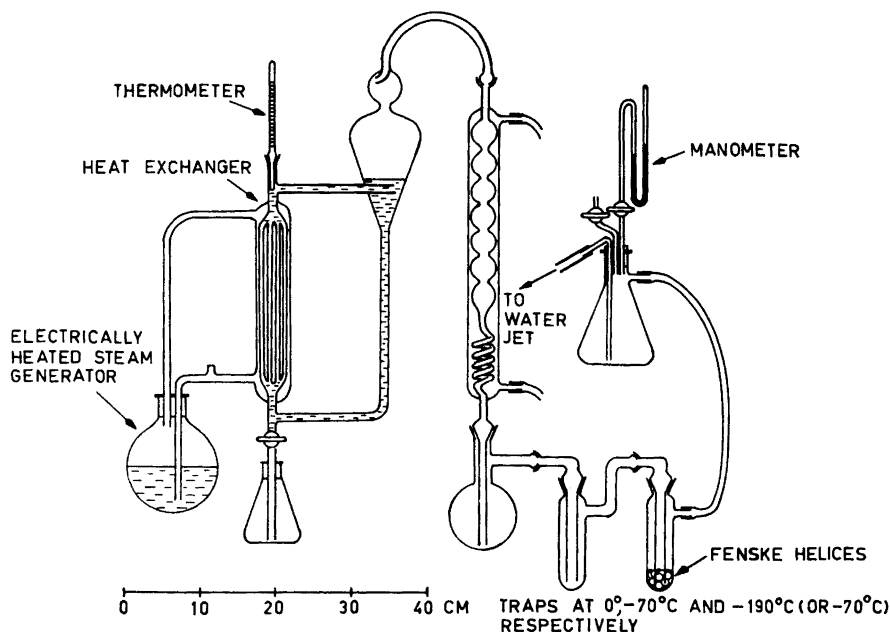

Fig. 1. Diagram of the distillation apparatus.

Recovery of flavour substances with boiling points of 100–250°C (at ordinary pressure) and with partition coefficients greater than 1 in the solvent system pentane-ether/water (satur. with NaCl) is fairly good. By using a liquid nitrogen trap in the distillation process and ethyl chloride as the extraction solvent, it is possible to reduce the losses of the lower (< 100°C) boiling compounds considerably. We have performed some distillations from water and milk, to which several organic compounds (esters, higher alcohols, carbonyl compounds, etc.) have been added (10–10 000 µg/litre). On distillation from water a recovery of 70–90 % was obtained for the higher-boiling compounds (150–250°C) and 50–70 % for the lower-boiling compounds (100–150°C), using only ice and two dry-ice traps, with pentane-ether as the extraction solvent. From milk, which contains 4–5 % of fat, the percentage recovery decreases very rapidly with increase of the molecular size. For example, only 15 % of the added ethyl decanoate was found in the concentrate. It is possible, however, qualitatively to demonstrate 10 µg of added ethyl decanoate from one litre of milk. The recovery of compounds with boiling points of 100–150°C from milk was about the same as from water.

This method is suitable for concentrations of 5 µg – 10 mg/litre (0.005–10 ppm). If the sample contains more than 10 mg/litre of a flavour compound, the sample must first be diluted with pure water. For the determination of carbonyl compounds we have modified this method so that the distilled carbonyls were converted directly after distillation with 2,4-dinitrophenylhydra-

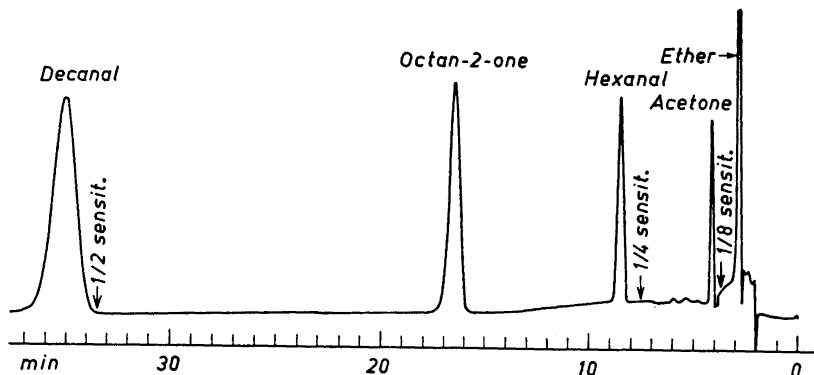

Fig. 2. Regeneration of a mixture of 4–5 µg each of 2,4-dinitrophenylhydrazones of acetone, hexanal, octan-2-one and decanal with α -ketoglutaric acid. The following recoveries were obtained: acetone 100 %, hexanal 98 %, octan-2-one 95 % and decanal 96 %.

zine to nonvolatile form. The 2,4-dinitrophenylhydrazones formed were then isolated by extraction with benzene and purified on ion-exchange resins according to the method of Schwartz *et al.*³ For the determination of the individual carbonyl compounds the pure 2,4-dinitrophenylhydrazones were regenerated with α -ketoglutaric acid for gas chromatographic analyses by a modification of the method earlier used by Ralls⁴ and Stephens *et al.*⁵ The recovery obtained by the regeneration process was found to be 95–100 % and the total recovery calculated from the added substances about 50 %. A typical run from the regeneration of pure 2,4-dinitrophenylhydrazones of some carbonyl compounds is shown in Fig. 2.

EXPERIMENTAL

Reagents and solvents. Sodium chloride and sodium sulphate (Merck, p.a.) were heated for 24 h at 250°C before use.

2,4-Dinitrophenylhydrazine solution was prepared by dissolving 500 mg of 2,4-dinitrophenylhydrazine (Merck, p.a.) in 1000 ml of 2 N hydrochloric acid and extracting this solution 5 times with carbonyl-free benzene (50 ml) for the removal of impurities.

α -Ketoglutaric acid solution was made by dissolving 50 mg of α -ketoglutaric acid (Fluka AG, *puriss.*) in 10 ml of pure ether.

Water was purified by boiling distilled water for half-an-hour in an open Erlenmeyer flask.

Pentane (Merck) and dry peroxide-free ether were distilled 3 times through a 75 cm high Widmer column in order to remove the high-boiling compounds.

Carbonyl-free methanol and benzene were prepared according to Schwartz *et al.*⁶

Purification of glassware. All glassware to be used in the determinations was first washed with 5 % alcoholic potassium hydroxide, then rinsed several times with water and allowed to stand overnight in a solution of potassium bichromate in conc. sulphuric acid. After thorough rinsing with pure water the glassware was heated for several hours at 150°C in a drying oven. All operations must be performed in a cool, well ventilated room, since the solvents very readily absorb organic compounds from the air.

Performance of the distillation. 250 ml of a liquid sample is sucked into the distillation apparatus through the stopcock (Fig. 1) and distilled at a pressure of 20–25 mm of mercury. During the distillation (30 min) 250 ml of pure water was fed in, so that the

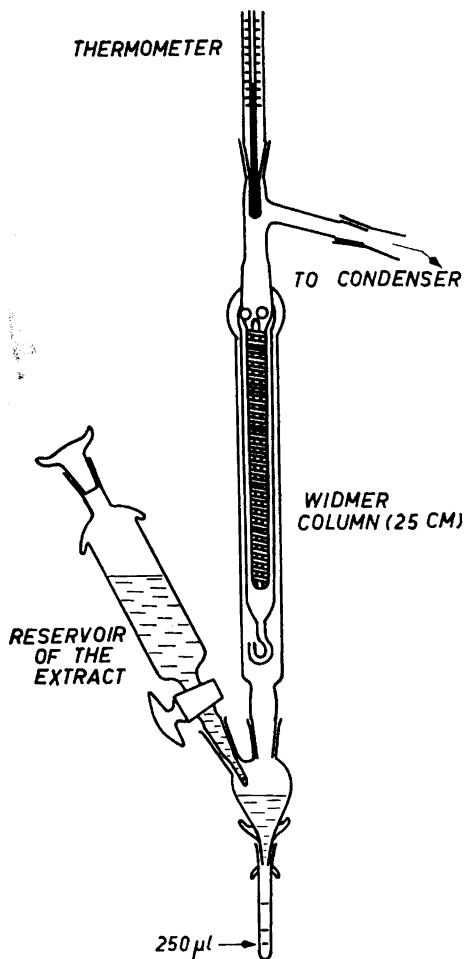

Fig. 3. A Widmer column distillation apparatus for the concentration of the flavour extract. The detachable and graduated tube at the lower end of the apparatus is placed in a thermostat (30°C or 60°C for ethyl chloride and pentane-ether, respectively) and closed with a Teflon stopper when the desired final volume has been reached.

level in the apparatus remained constant. The distillates in the traps were transferred to a separatory funnel (no grease should be used in the stopcocks) and the traps washed, first twice with 50 ml of pure water and then once with 50 ml of a mixture of pentane-ether (1:1). After addition of pure sodium chloride the organic layer was separated and the aqueous solution extracted once again with 50 ml of pentane-ether. The combined extracts were dried over sodium sulphate (5 g), filtered and concentrated in a Widmer column distillation apparatus (Fig. 3) to a final volume of 250 μ l. A known quantity (10–50 μ l) of this concentrate was fed into the gas chromatographic column from a U-tube by means of a 4-way valve (Fig. 4, 5). A "Fraktometer" of the Perkin Elmer Co. with a flame ionization detector, a column "K" (polyethylene glycol, 600 cm, i.d. 4.5 mm) at 175°C and a nitrogen flow of 45 ml/min was used. The area of the peaks was determined with a planimeter. The special response of the substances tested varied from 15 to 30 cm^2 per μg of a substance at the greatest sensitivity. (A 2.5 mV Honeywell recorder with a chart speed of 2/3 inch/min was used). It is also possible to add a known quantity

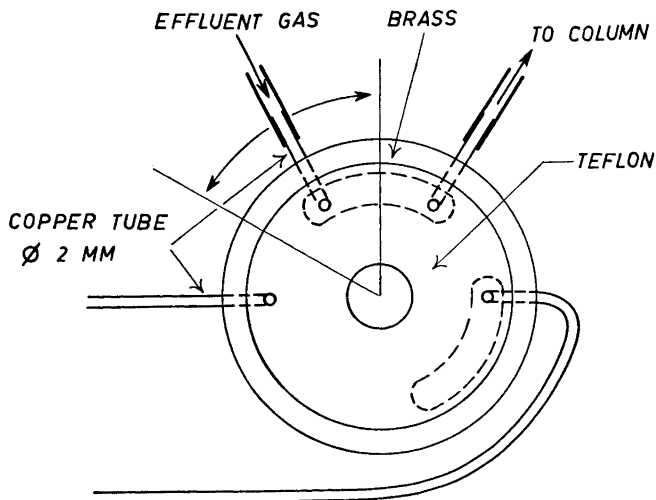

Fig. 4. The design of the 4-way sample inlet valve.

of a suitable reference compound to the sample before distillation and calculate the amount of other compounds on the basis of the area of the reference peak.

For determination of the carbonyl compounds a total of 100 ml of 2,4-dinitrophenylhydrazine solution was added to the traps after distillation. The solutions from the traps were transferred to a separatory funnel and the traps washed, first twice with 50 ml of pure water and then with 50 ml of carbonyl-free benzene. After the solution had stood for one hour at room temperature, the benzene layer was separated and the aqueous solution extracted twice with 25 ml of benzene. The 2,4-dinitrophenylhydrazones formed

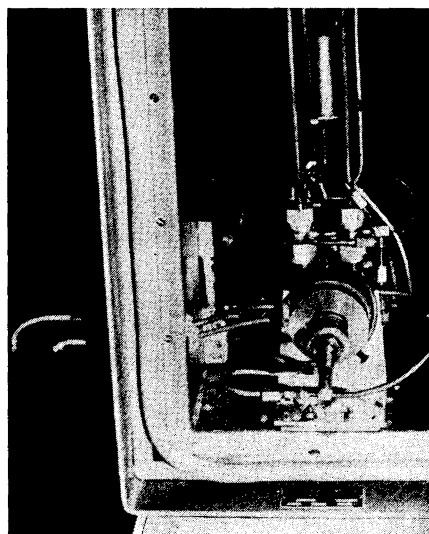

Fig. 5. Photograph showing the location of the sample inlet valve in the gas chromatography apparatus.

were purified by the method of Schwartz *et al.*³ The pure 2,4-dinitrophenylhydrazones were then dissolved in 10 ml of pure ether in a volumetric flask and 10–100 μ l of this solution was transferred to a U-tube. Ether was evaporated by bubbling air through the U-tube. 100 μ l of the ether solution of α -ketoglutaric acid was then added and the ether was evaporated as rapidly as possible. The U-tube was then fastened to the 4-way valve (Fig. 4, 5) with two Teflon tubes (i.d. 2 mm) and heated for 60 sec. at 250°C in a silicone-oil bath. The regenerated carbonyl compounds were then eluted from the U-tube (in 30 sec) to the column by turning the valve.

To check the purity of the solvents and apparatus, a blank was made first by distilling pure water (250 ml) in the distillation apparatus.

Our thanks are due to Professor A. I. Virtanen for his interest in this work. This research has been financed in part by a grant made by *United States Department of Agriculture, Agricultural Research Service.*

REFERENCES

1. Weurman, C. J. *Food Sci.* **26** (1961) 670.
2. Strating, J. and Venema, A. J. *Inst. Brewing* **67** (1961) 525.
3. Schwartz, D., Johnson, A. and Parks, O. *Microchem. J.* **6** (1962) 37.
4. Ralls, J. *Anal. Chem.* **32** (1960) 332.
5. Stephens, R. and Teszler, A. *Anal. Chem.* **32** (1960) 1047.
6. Schwartz, D. and Parks, O. *Anal. Chem.* **33** (1961) 1396.

Received February 4, 1963.